

MM248**LIGHT-SENSE ON CHIP NEAR MOTION TRIGGER ASIC****DATA SHEET****FEATURES**

- Wide battery operating voltage : 2.4V to 5.1V.
- Typical operating current : 500 μ A, $V_{DD} = 4.5V$.
- Trigger pulse with controlled width on valid detection
- Hold input for operation suspension
- Built in inhibit period for stable operation
- Sensitivity adjustable with external component
- Adaptive to environmental background illumination
- Built in filter for rejecting power line frequencies (50/60Hz)
- Built in voltage regulator for stable operation

GENERAL DESCRIPTION

Light-Sense on chip sensor near motion trigger MM248 offers simplicity and flexibility for applications on the proximity light screen. With the on-chip photo sensor it is a cost effective solution and enhances system performance with its stability and consistency characteristics.

With the on-chip (on the top of the die) photo sensor, MM248 detects the small change in the light intensity for a close moving objects, e.g., hand shake. When an object falls into the sensing area for longer than 500ms, the chip generates a trigger signal at the time the object moves away. The trigger signal is 66ms wide. After the signal, the chip enters the inhibition period of 130ms where no light change is responded. The chip is back to normal after this period.

The trigger signal can be disabled by applying a high voltage level to the HOLD input pin. When this HOLD pin is released, the chip is back to normal in about 2 seconds.

In the indoor environment MM248 operates good. When there is close to no lighting (typically below 50 Lux), the chip enters the sleep mode. When there is a light, the chip is back to normal in about 2 seconds.

PIN DEFINITION

Pin #	Pin Name	Description
1	TEST	test pin no connection
2	VREG	regulated power supply output
3	ROFF	current input connect to resistor ROFF for dark level adjustment the suggested value is 360Kohm (# check the application note for implementation)
4	VIN	analog input connect to capacitor CIN
5	DIN	analog input connect to capacitor CIN
6	G1	gain control connect to capacitor CG
7	G2	gain control connect to capacitor CG
8	VSS	negative power supply
9	HOLD	high voltage level to disable TRIG low voltage level to enable TRIG
10	TRIG	trigger signal output
11	VDD	positive power supply

PAD DIAGRAM

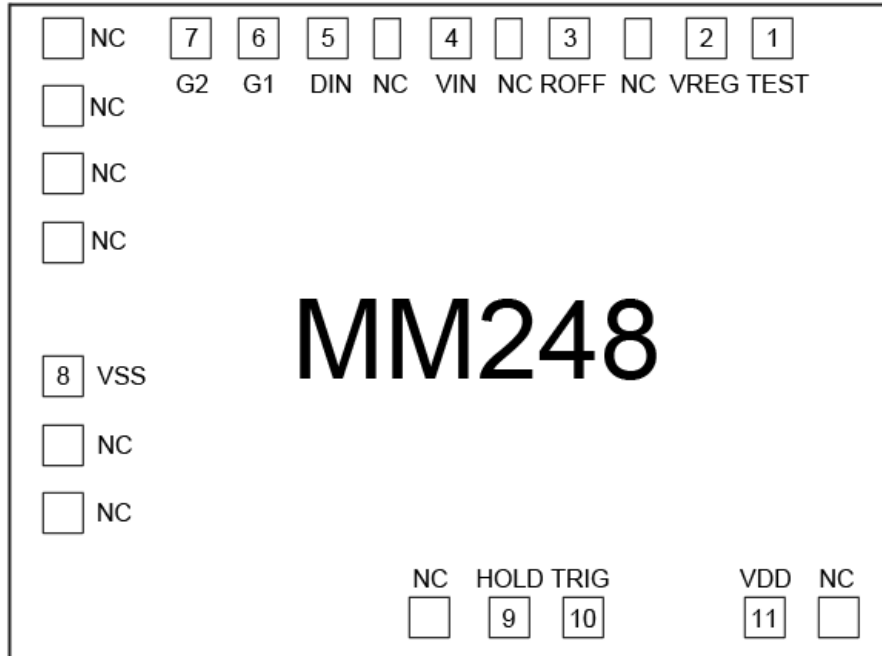

Substrate connects to VDD
NC pads are no connection

ELECTRICAL CHARACTERISTICS

Absolute Maximum Ratings

V_{SS} = 0V, Ambient Temperature = 25°C

PARAMETER	SYMBOL	TEST CONDITIONS	LIMITS	UNIT
Supply Voltage	V _{DD}	-	5.1	V
Input Voltage	V _{IN}	-	-0.3 to V _{DD} +0.3	V
Operation Temperature	T _{OP}	-	0 to 55	°C
Storage Temperature	T _{ST}	-	-25 to 125	°C

Absolute maximum ratings are the values beyond which the safety of the device cannot be guaranteed

AC & DC Characteristics

V_{SS} = 0V, V_{DD} = 4.5V, Ambient Temperature = 25°C (unless otherwise specified)

R_{OFF} = 360Kohm

PARAMETER	SYMBOL	TEST CONDITIONS	LIMITS			UNIT
			MIN	TYP	MAX	
Operating Voltage	V _{DD} - V _{SS}	-	2.4	4.5	5.1	V
Operating Current	I _{DD}	No Load ^{#1} , V _{DD} = 3.0V	-	400	800	μA
		No Load ^{#1} , V _{DD} = 4.5V	-	500	1000	μA
Sleep Current	I _{SLEEP}	No Load, V _{DD} = 3.0V	-	50	100	μA
		No Load, V _{DD} = 4.5V	-	100	200	μA
Oscillation Frequency	F _{OSC}	Built-in R _{OSC}	103	128	153	KHz
Operating Photo Current ^{#2 #3}	I _{PH_OP}	-	1	4	8	μA
Sleeping Photo Current ^{#2 #4}	I _{PH_SL}	-	0.1	0.3	0.8	μA
Input High Voltage	V _{IH}	-	V _{DD} -0.3	-	V _{DD}	V
Input Low Voltage	V _{IL}	-	V _{SS}	-	V _{SS} +0.3	V
HOLD Input High Current	I _{IH(HOLD)}	-	1	20	100	μA
TRIG Output High Voltage	V _{OH(TRIG)}	I _{OH} = 2mA	V _{DD} -0.8	-	-	V
TRIG Output Low Voltage	V _{OL(TRIG)}	I _{OL} = -1μA	-	-	V _{SS} +0.8	V

Note 1 : Supply current is measured with oscillator running.

Note 2 : It is measured by connecting TEST and VREG with an ammeter. The operation of the chip is interrupted during the measurement.

Note 3 : It achieves the optimal performance when the photo current falls between the MAX and MIN LIMITS of I_{PH_OP}

Note 4 : It enters the sleep mode when the photo current falls below the LIMITS of I_{PH_SL}

TYPICAL APPLICATION CIRCUIT

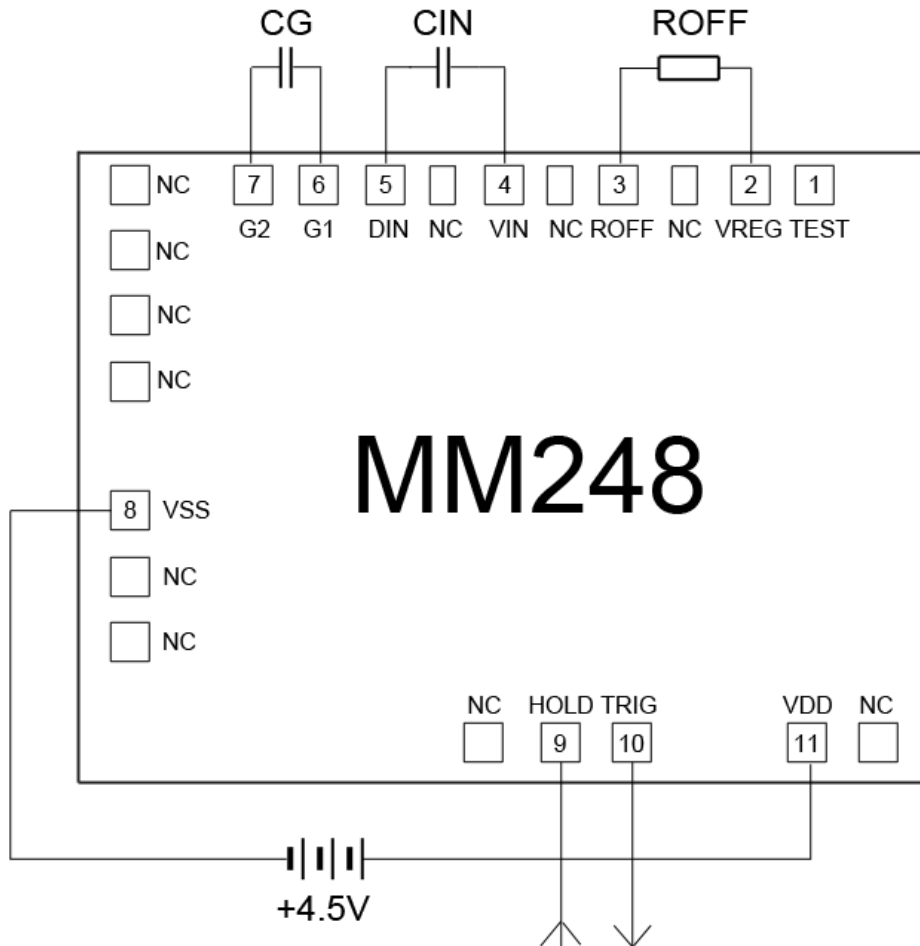

Substrate connects to VDD
 NC pads are no connection

Typical values : CG = 68nF
 CIN = 330nF
 ROFF = 360Kohm

HOLD : high voltage level to disable TRIG
 low voltage level to enable TRIG

IMPORTANT NOTICE

AMOS Technology Limited reserves the right to make changes in the circuitry and the specification of this chip without prior notice. Customers are advised to check AMOS for the latest information.