

# MM243 DATASHEET

## LIGHT-SENSE with Voice

### Features

- Wide battery operating voltage range: 2.4V to 5.1V
- Typical operating current : 200uA, Vdd = 3.0V
- Built in inhibit period for stable operation
- High sensitivity (adjustable with external component)
- Adaptive to environmental background illumination
- Built in filter for rejecting power line frequencies (50/60Hz)
- Built in Voltage Regulator for stable operation
- Embedded mask ROM for custom voice
- One second voice length at 6KHz sampling and 5-bit APCM compression
- User selectable sampling frequency 12/8/6/4.8/4/3KHz (Mask programmable options)
- Repeat playback mode to extend duration (Mask programmable options)
  - Play 1/2/3/endless
- PWM output drive 32-ohm speaker directly

### General Description

AMOS Light-Sense with built-in voice MM243 offers high sensitivity, simplicity and flexibility for applications on detecting small signal changes. With the on-board chip it is a cost effective solution and enhances system performance with its stability and consistency characteristics.

By the on-board photo-transistor as the input sensor to the chip MM243, MM243 will detect for small light intensity changes caused by moving objects in the detection range, custom voice will be played upon valid detection. The chip drives the 32-ohm speaker directly.

When the environment lighting is below the defined application operating range, MM243 will enter the inhibit mode, detection is disabled. When the environment lighting changes from below to within the defined application operating lighting range, detection will be enabled after around 2+ sec.

### Pin Definition

<b>Pin#</b>	<b>Pin Name</b>	<b>Function</b>
1	VSSA	connects to negative terminal of power supply.
2	OSCR	connects to Rosc.
3	VDDA	connects to positive terminal of power supply.
4	VSS	connects to negative terminal of power supply.
5	SP2	connects to buzzer/speaker.
6	SP1	connects to buzzer/speaker.
7	VDD	connects to positive terminal of power supply.
8	SLEEPB	option pin, default low.
9	VREG	regulated power supply.
10	ROFF	connects to Roff.

11	RIN	connects to emitter of phototransistor.
12	VIN	connects to Cin.
13	DIN	connects to Cin.
14	G1	connects to Cg.
15	G2	connects to Cg.
16	D2LB	option pin, default low.
17	L2DB	option pin, default low.

## Electrical Characteristics

### Absolute Maximum Ratings

V<sub>SS</sub>=0V, ambient temp. = 25 degree C

PARAMETER	SYMBOL	TEST CONDITIONS OR COMMENTS	LIMITS	UNIT
Supply Voltage	V <sub>DD</sub>	-	5.1	V
Input Voltage	V <sub>IN</sub>	-	-0.3 to V <sub>DD</sub> + 0.3	V
Operation Temperature	T <sub>OP</sub>	-	0 to 55	Deg C
Storage Temperature	T <sub>ST</sub>	-	-25 to 125	Deg C

Absolute Maximum Rating are values beyond which the safety of the device cannot be guaranteed.

### A.C. & D.C. Characteristics

V<sub>DD</sub> = 3.0V, V<sub>SS</sub> = 0V, R<sub>off</sub>=360KΩ, R<sub>osc</sub>=200KΩ, ambient temperature = 25 Degree C (unless otherwise specified).

PARAMETER	SYMBOL	TEST	LIMITS			
			MIN	TYP	MAX	
Operating Voltage	V <sub>DD</sub> - V <sub>SS</sub>	-	2.4	3.0	5.1	V
Operating Current	I <sub>DD</sub>	Unloaded (1), V <sub>DD</sub> = 3.0V	-	200	400	uA
		Unloaded (1), V <sub>DD</sub> = 4.5V				
Oscillation Frequency	F <sub>OSC</sub>	R <sub>OSC</sub> = 200KΩ	0.8	1	1.25	MHz
Sleep Current	I <sub>SLEEP</sub>	RIN=VREG(2), V <sub>DD</sub> = 3.0V	-	50	100	uA
		RIN=VREG(2), V <sub>DD</sub> = 4.5V		80	150	
Photo Current	I <sub>PHOTO</sub>	(3)	4	-	36	uA
Sleep Mode Current Threshold	I <sub>SLEEP_TH</sub>	-	-	0.5	-	uA
Input High Voltage	V <sub>IH</sub>	-	V <sub>DD</sub> -0.3	-	V <sub>DD</sub>	V
Input Low Voltage	V <sub>IL</sub>	-	V <sub>SS</sub>	-	V <sub>SS</sub> +0.3	V

AMOS reserves the right to make changes in the circuitry and specification of the chip without notice, customers are advised to check AMOS on the latest information.

Note 1: Supply current is measured with oscillator running.

Note 2: Enter sleep mode if phototransistor current is below sleep mode current threshold for approx. 2 second.

Note 3: Optimum performance when photo-transistor current is between 4uA to 36uA.

## Typical Application Diagram

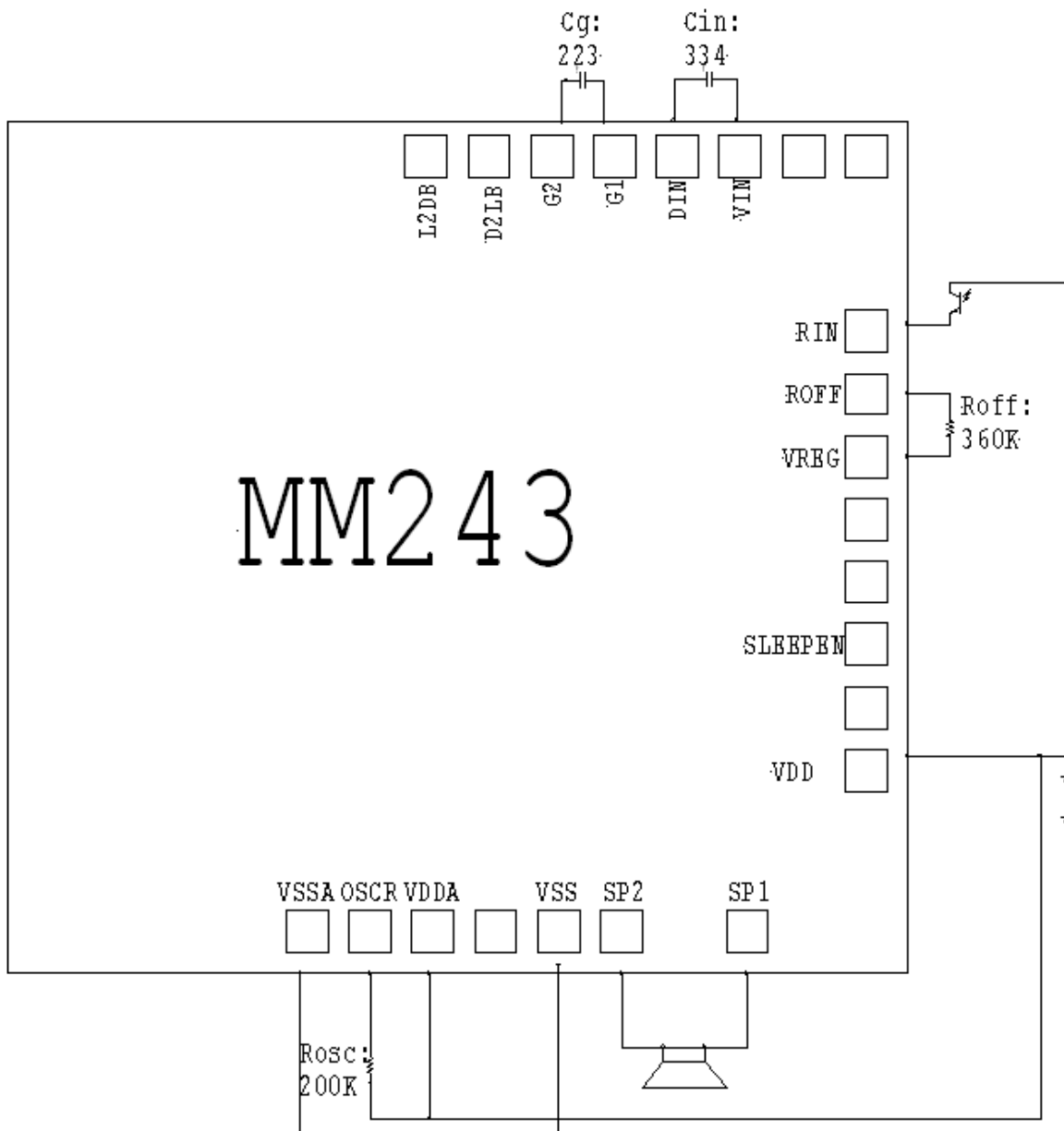

Remark : Substrate connects to Vdd.