

MM236 DATASHEET

Sound-Sense LED driver

Features

- Wide operating voltage to support 2-battery and 3-battery system
- Low operating current
- Direct drive LED

General Description

AMOS MM236 provides a cost effective single chip solution for sound detection devices with LED output, a piezo buzzer is used to pick up the sound and convert the signal to drive the LED. When power up, there's an inhibit period of 0.5sec to 2.0sec before detection begins, light patterns will be played once being triggered. Sensitivity is related to the mechanical construction and efficiency of the piezo buffer, the expected R_{sense} is around 3.3M and may need final adjustment depending on the mechanical constructions and the desirable effect, factory decision.

Pin Definition

Pin#	Pin Name	Function
1	C2	connects to Cap
2	C1	connects to Cap
3	Vdd	connects to positive terminal of power supply.
4	BUZ1	connects to buzzer*
5	BUZ2	connects to buzzer*
6	Vss	connects to negative terminal of power supply.
7	LED	connects to LED.

* also connects to R_{sense} for sensitivity trimming.

Electrical Characteristics

Absolute Maximum Ratings

$V_{SS}=0V$, ambient temp. = 25 degree C

PARAMETER	SYMBOL	TEST CONDITIONS OR COMMENTS	LIMITS	UNIT
Supply Voltage	V_{DD}	-	5.1	V
Input Voltage	V_{IN}	-	-0.3 to $V_{DD} + 0.3$	V
Operation Temperature	T_{OP}	-	0 to 55	Deg C
Storage Temperature	T_{ST}	-	-25 to 125	Deg C

Absolute Maximum Rating are values beyond which the safety of the device cannot be guaranteed.

A.C. & D.C. Characteristics

$V_{DD} = 3.0V$, $V_{SS} = 0V$, ambient temperature = 25 Degree C (unless otherwise specified).

PARAMETER	SYMBOL	TEST CONDITION	LIMITS			
			MIN	TYP	MAX	
Operating Voltage	$V_{DD} - V_{SS}$	-	2.4	3.0	5.1	V
Operating Current	I_{DD}	No Load	-	100	-	uA
Oscillation Frequency	Fosc	Built-in Rosc	-	128	-	kHz
Trigger Voltage	V trigger	BUZ1- BUZ2	800	-	-	uV
Silence Voltage	V silence	BUZ1- BUZ2	-	-	200	uV
Input High Voltage	V_{IH}	-	$V_{DD} - 0.3$	-	V_{DD}	V
Input Low Voltage	V_{IL}	-	V_{SS}	-	$V_{SS} + 0.3$	V
LED Output Low Voltage	V_{OL}	$I_{OL} = -5mA$	-	-	$V_{SS} + 0.8$	V

AMOS reserves the right to make changes in the circuitry and specification of the chip without notice, customers are advised to check AMOS on the latest information.

Typical Application Diagram

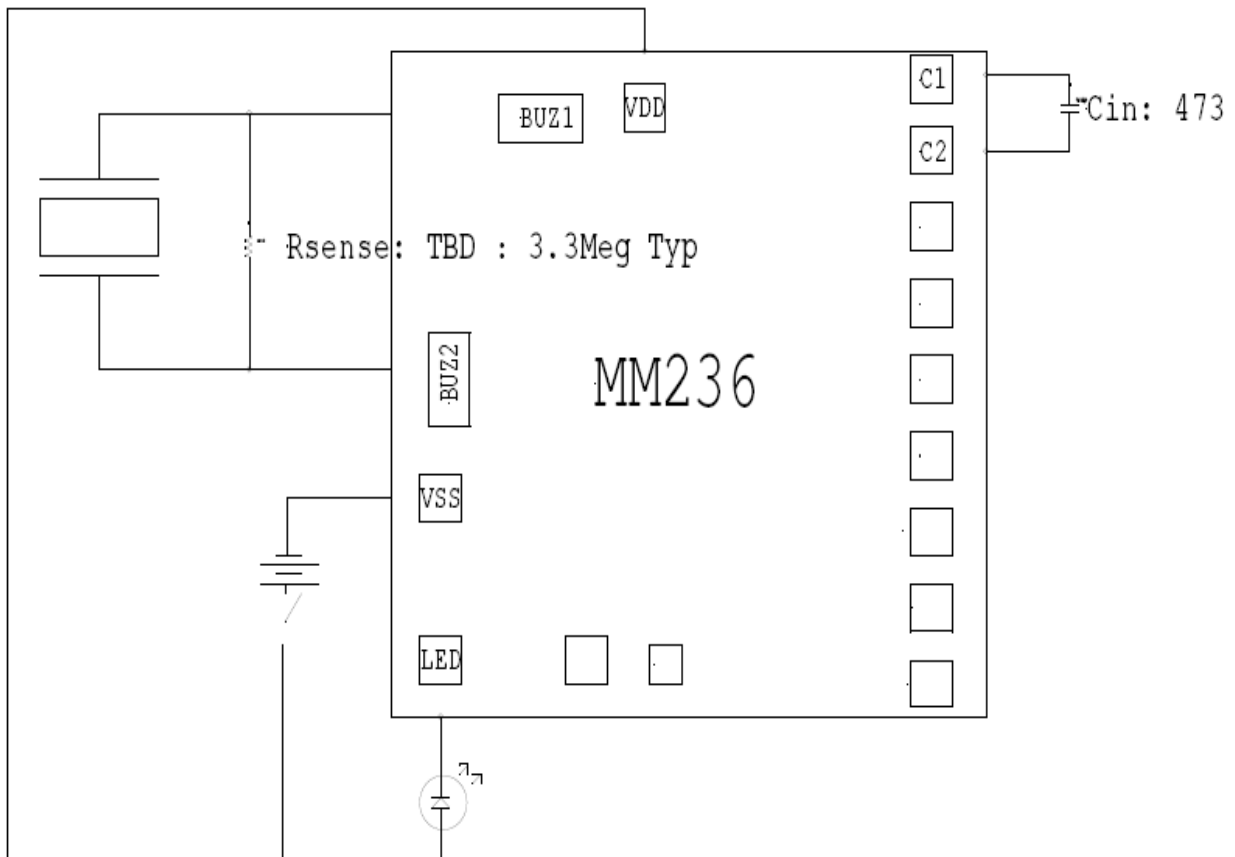

Remark : Substrate connects to Vdd.