



Low Quiescent Current_Low Dropout CMOS Voltage Regulator

AMS53XX Series 500mA

The AMS53XX series is a family of Low Quiescent Low Dropout Positive regulators. developed using CMOS technology.

These ICS perform with high output voltage accuracy, low quiescent current , Output current 500mA,

The allow operation voltage as high as 10V.

■ Feature:

- high output voltage accuracy $\pm 2\%$
- low dropout voltage 1.5mV $I_{out}=1mA$
- low quiescent current 1.2uA
- Max input voltage 10V
- Output current 500mA

■ Applications

- Power source for home electric/electronic appliances
- Power source for battery-powered devices
- Power source for personal communication devices

■ Selection table

Part NO.	Output voltage (Note)	Tolerance	MARK SOT-89 TO-92	MARK SOT-23-3
AMS5312	1.2V	$\pm 2\%$	MD5-12	M512
AMS5315	1.5V	$\pm 2\%$	MD5-15	M515
AMS5318	1.8V	$\pm 2\%$	MD5-18	M518
AMS5321	2.1V	$\pm 2\%$	MD5-21	M521
AMS5325	2.5V	$\pm 2\%$	MD5-25	M525
AMS5327	2.7V	$\pm 2\%$	MD5-27	M527
AMS5328	2.8V	$\pm 2\%$	MD5-28	M528
AMS5330	3.0V	$\pm 2\%$	MD5-30	M530
AMS5333	3.3V	$\pm 2\%$	MD5-33	M533
AMS5336	3.6V	$\pm 2\%$	MD5-36	M536
AMS5338	3.8V	$\pm 2\%$	MD5-38	M538
AMS5344	4.4V	$\pm 2\%$	MD5-44	M544
AMS5350	5.0V	$\pm 2\%$	MD5-50	M550

NOTE: for semi_custom parts selectable output voltage from 1.2~7.0V in 0.1v increment

■ Package and Pin Assignment

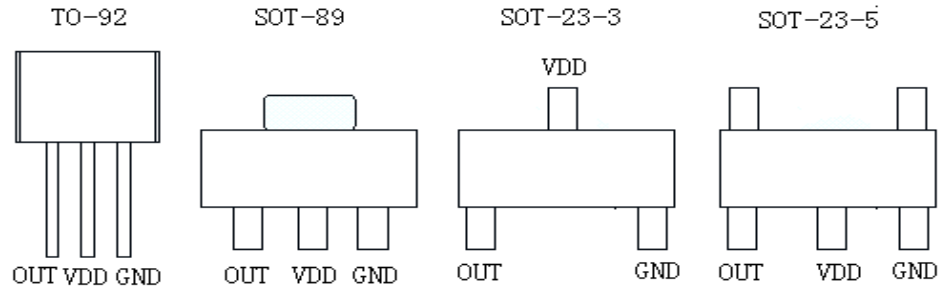

Figure 1

Absolute Maximum Ratings: (Ta=25°C unless otherwise specified)

Item	Symbol	Absolute Maximum Ratings	Unit
Input voltage	V _{IN}	12	V
Output voltage	V _{OUT}	V _{SS} -0.3 ~ V _{IN} +0.3	
Power dissipation	P _D	SOT_89 500 TO_92 300 SOT_23 200	Mw
Operation temperature range	T _{opr}	-40 ~ +85	°C
Storage temperature range	T _{stg}	-40 ~ +125	

Caution The absolute maximum ratings are rated values exceeding which the product could suffer physical damage. These values must therefore not be exceeded under any conditions.

Electrical Characteristics:

AMS53XX series (MD5312, Output voltage +1.2V) (Ta=25°C unless otherwise specified)

ITEM	SYMBOL	CONDITIONS	MIN	TYPE	MAX	UNITS	Test circuits
Output voltage	V _{OUT}	V _{IN} =2.2V, I _{OUT} =40mA	1.176	1.2	1.224	V	1
Output current *1	I _{OUT}	V _{IN} =2.2V	180			mA	3
Dropout voltage *2	V _{drop}	I _{OUT} =10 mA I _{OUT} =100 mA		25 280	35 380	mV	1
Line regulation	$\frac{\Delta V_{OUT1}}{\Delta V_{IN} \cdot V_{OUT}}$	2.2V ≤ V _{IN} ≤ 10V I _{OUT} =10mA		0.05	0.2	%/V	
Load regulation	ΔV_{OUT2}	V _{IN} =2.2V 1.0mA ≤ I _{OUT} ≤ 100mA		15	30	mV	
Temperature coefficient	$\frac{\Delta V_{OUT}}{\Delta T_a \cdot V_{OUT}}$	V _{IN} =2.2V, I _{OUT} =1mA -40°C ≤ T _a ≤ 85°C		±50	±100	Ppm/°C	
Current consumption	I _{SS1}	V _{IN} =10V No Load		1.2	2.5	uA	2
Input voltage	V _{IN}	--			10	V	
Short current limit	I _{lim}	V _{out} =0V		50	70	mA	

AMS53XX series(MD5315, Output voltage +1.5V) (Ta=25°C unless otherwise specified)

ITEM	SYMBOL	CONDITIONS	MIN	TYPE	MAX	UNITS	Test circuits
Output voltage	V _{OUT}	V _{IN} =2.5V, I _{OUT} =40mA	1.470	1.5	1.530	V	1
Output current *1	I _{OUT}	V _{IN} =2.5V	220			mA	3
Dropout voltage *2	V _{drop}	I _{OUT} =10 mA I _{OUT} =100 mA		20 200	28 280	mV	1
Line regulation	$\frac{\Delta V_{OUT1}}{\Delta V_{IN} \cdot V_{OUT}}$	2.5V ≤ V _{IN} ≤ 10V I _{OUT} =10mA		0.05	0.2	%/V	
Load regulation	ΔV _{OUT2}	V _{IN} =2.5V 1.0mA ≤ I _{OUT} ≤ 100mA		15	30	mV	
Temperature coefficient	$\frac{\Delta V_{OUT}}{\Delta T_a \cdot V_{OUT}}$	V _{IN} =2.5V, I _{OUT} =1mA -40°C ≤ T _a ≤ 85°C		±50	±100	Ppm/°C	
Current consumption	I _{SS1}	V _{IN} =10V No Load		1.2	2.5	μA	2
Input voltage	V _{IN}	--			10	V	
Short current limit	I _{lim}	V _{out} =0V		50	70	mA	

AMS53XX series(MD5318, Output voltage +1.8V) (Ta=25°C unless otherwise specified)

ITEM	SYMBOL	CONDITIONS	MIN	TYPE	MAX	UNITS	Test circuits
Output voltage	V _{OUT}	V _{IN} =2.8V, I _{OUT} =40mA	1.764	1.8	1.836	V	1
Output current *1	I _{OUT}	V _{IN} =2.8V	280			mA	3
Dropout voltage *2	V _{drop}	I _{OUT} =10 mA I _{OUT} =100 mA		15 140	21 210	mV	1
Line regulation	$\frac{\Delta V_{OUT1}}{\Delta V_{IN} \cdot V_{OUT}}$	2.8V ≤ V _{IN} ≤ 10V I _{OUT} =1mA		0.05	0.2	%/V	
Load regulation	ΔV _{OUT2}	V _{IN} =2.8V 1.0mA ≤ I _{OUT} ≤ 150mA		30	45	mV	
Temperature coefficient	$\frac{\Delta V_{OUT}}{\Delta T_a \cdot V_{OUT}}$	V _{IN} =2.8V, I _{OUT} =1mA -40°C ≤ T _a ≤ 85°C		±50	±100	Ppm/°C	
Current consumption	I _{SS1}	V _{IN} =10V No Load		1.2	2.5	μA	2
Input voltage	V _{IN}	--			10	V	
Short current limit	I _{lim}	V _{out} =0V		50	70	mA	

AMS53XX series(MD5321, Output voltage +2.1V) (Ta=25°C unless otherwise specified)

ITEM	SYMBOL	CONDITIONS	MIN	TYPE	MAX	UNITS	Test circuits
Output voltage	V _{OUT}	V _{IN} = 3.1V, I _{OUT} =40mA	2.058	2.1	2.142	V	1
Output current *1	I _{OUT}	V _{IN} = 3.1V	320			mA	3
Dropout voltage *2	V _{drop}	I _{OUT} =10 mA I _{OUT} =100 mA		13 130	18 180	mV	1
Line regulation	$\frac{\Delta V_{OUT1}}{\Delta V_{IN} \cdot V_{OUT}}$	3.1V ≤ V _{IN} ≤ 10V I _{OUT} =1mA		0.05	0.2	%/V	
Load regulation	ΔV _{OUT2}	V _{IN} =3.1V 1.0mA ≤ I _{OUT} ≤ 150mA		30	45	mV	
Temperature coefficient	$\frac{\Delta V_{OUT}}{\Delta T_a \cdot V_{OUT}}$	V _{IN} =3.1V, I _{OUT} =10mA -40°C ≤ T _a ≤ 85°C		±50	±100	Ppm/°C	
Current consumption	I _{SS1}	V _{IN} =10V No Load		1.2	2.5	μA	2
Input voltage	V _{IN}	--			10	V	
Short current limit	I _{lim}	V _{out} =0V		50	70	mA	

AMS53XX series(MD5325, Output voltage +2.5V) (Ta=25°C unless otherwise specified)

ITEM	SYMBOL	CONDITIONS	MIN	TYPE	MAX	UNITS	Test circuits
Output voltage	V _{OUT}	V _{IN} = 3.5V, I _{OUT} =50mA	2.450	2.5	2.550	V	1
Output current *1	I _{OUT}	V _{IN} = 3.5V	350			mA	3
Dropout voltage *2	V _{drop}	I _{OUT} =10 mA I _{OUT} =100 mA		12 120	17 170	mV	1
Line regulation	$\frac{\Delta V_{OUT1}}{\Delta V_{IN} \cdot V_{OUT}}$	3.5V ≤ V _{IN} ≤ 10V I _{OUT} =1mA		0.05	0.2	%/V	
Load regulation	ΔV _{OUT2}	V _{IN} =3.5V 1.0mA ≤ I _{OUT} ≤ 150mA		30	45	mV	
Temperature coefficient	$\frac{\Delta V_{OUT}}{\Delta T_a \cdot V_{OUT}}$	V _{IN} =3.5V, I _{OUT} =10mA -40°C ≤ T _a ≤ 85°C		±50	±100	Ppm/°C	
Current consumption	I _{SS1}	V _{IN} =10V No Load		1.2	2.5	μA	2
Input voltage	V _{IN}	--			10	V	
Short current limit	I _{lim}	V _{out} =0V		50	70	mA	

AMS53XX series(MD5327, Output voltage +2.7V) (Ta=25°C unless otherwise specified)

ITEM	SYMBOL	CONDITIONS	MIN	TYPE	MAX	UNITS	Test circuits
Output voltage	V _{OUT}	V _{IN} = 3.7V, I _{OUT} =50mA	2.646	2.7	2.754	V	1
Output current *1	I _{OUT}	V _{IN} = 3.7V	400			mA	3
Dropout voltage *2	V _{drop}	I _{OUT} =10 mA I _{OUT} =200 mA		12 220	18 300	mV	1
Line regulation	$\frac{\Delta V_{OUT1}}{\Delta V_{IN} \cdot V_{OUT}}$	3.7V ≤ V _{IN} ≤ 10V I _{OUT} =1mA		0.05	0.2	%/V	
Load regulation	ΔV _{OUT2}	V _{IN} =3.7V 1.0mA ≤ I _{OUT} ≤ 150mA		25	40	mV	
Temperature coefficient	$\frac{\Delta V_{OUT}}{\Delta T_a \cdot V_{OUT}}$	V _{IN} =3.7V, I _{OUT} =10mA -40°C ≤ T _a ≤ 85°C		±50	±100	Ppm/°C	
Current consumption	I _{SS1}	V _{IN} =10V No Load		1.2	2.5	μA	2
Input voltage	V _{IN}	--			10	V	
Short current limit	I _{lim}	V _{out} =0V		50	70	mA	

AMS53XX series(MD5328, Output voltage +2.8V) (Ta=25°C unless otherwise specified)

ITEM	SYMBOL	CONDITIONS	MIN	TYPE	MAX	UNITS	Test circuits
Output voltage	V _{OUT}	V _{IN} = 3.8V, I _{OUT} =50mA	2.744	2.8	2.856	V	1
Output current *1	I _{OUT}	V _{IN} = 3.8V	400			mA	3
Dropout voltage *2	V _{drop}	I _{OUT} =10 mA I _{OUT} =200 mA		12 220	18 300	mV	1
Line regulation	$\frac{\Delta V_{OUT1}}{\Delta V_{IN} \cdot V_{OUT}}$	3.8V ≤ V _{IN} ≤ 10V I _{OUT} =1mA		0.05	0.2	%/V	
Load regulation	ΔV _{OUT2}	V _{IN} =3.8V 1.0mA ≤ I _{OUT} ≤ 150mA		25	40	mV	
Temperature coefficient	$\frac{\Delta V_{OUT}}{\Delta T_a \cdot V_{OUT}}$	V _{IN} =3.8V, I _{OUT} =10mA -40°C ≤ T _a ≤ 85°C		±50	±100	Ppm/°C	
Current consumption	I _{SS1}	V _{IN} =10V No Load		1.2	2.5	μA	2
Input voltage	V _{IN}	--			10	V	
Short current limit	I _{lim}	V _{out} =0V		50	70	mA	

AMS53XX series(MD5330, Output voltage +3.0V) (Ta=25°C unless otherwise specified)

ITEM	SYMBOL	CONDITIONS	MIN	TYPE	MAX	UNITS	Test circuits
Output voltage	V _{OUT}	V _{IN} = 4V, I _{OUT} =50mA	2.940	3.0	3.060	V	1
Output current *1	I _{OUT}	V _{IN} = 4V	450			mA	3
Dropout voltage *2	V _{drop}	I _{OUT} =10 mA I _{OUT} =200 mA		10 200	14 280	mV	1
Line regulation	$\frac{\Delta V_{OUT1}}{\Delta V_{IN} \cdot V_{OUT}}$	4V ≤ V _{IN} ≤ 10V I _{OUT} =1mA		0.05	0.2	%/V	
Load regulation	ΔV _{OUT2}	V _{IN} =4V 1.0mA ≤ I _{OUT} ≤ 200mA		30	45	mV	
Temperature coefficient	$\frac{\Delta V_{OUT}}{\Delta T_a \cdot V_{OUT}}$	V _{IN} =4V, I _{OUT} =10mA -40°C ≤ T _a ≤ 85°C		±50	±100	Ppm/°C	
Current consumption	I _{SS1}	V _{IN} =10V No Load		1.2	2.5	μA	2
Input voltage	V _{IN}	--			10	V	
Short current limit	I _{lim}	V _{out} =0V		50	70	mA	

AMS53XX series(MD5333, Output voltage +3.3V) (Ta=25°C unless otherwise specified)

ITEM	SYMBOL	CONDITIONS	MIN	TYPE	MAX	UNITS	Test circuits
Output voltage	V _{OUT}	V _{IN} = 4.3V, I _{OUT} =50mA	3.234	3.3	3.366	V	1
Output current *1	I _{OUT}	V _{IN} = 4.3V	500			mA	3
Dropout voltage *2	V _{drop}	I _{OUT} =10 mA I _{OUT} =200 mA		10 200	14 280	mV	1
Line regulation	$\frac{\Delta V_{OUT1}}{\Delta V_{IN} \cdot V_{OUT}}$	4.3V ≤ V _{IN} ≤ 10V I _{OUT} =1mA		0.05	0.2	%/V	
Load regulation	ΔV _{OUT2}	V _{IN} =4.3V 1.0mA ≤ I _{OUT} ≤ 200mA		30	45	mV	
Temperature coefficient	$\frac{\Delta V_{OUT}}{\Delta T_a \cdot V_{OUT}}$	V _{IN} =4.3V, I _{OUT} =10mA -40°C ≤ T _a ≤ 85°C		±50	±100	Ppm/°C	
Current consumption	I _{SS1}	V _{IN} =10V No Load		1.2	2.5	μA	2
Input voltage	V _{IN}	--			10	V	
Short current limit	I _{lim}	V _{out} =0V		50	70	mA	

AMS53XX series (MD5336, Output voltage +3.6V) (Ta=25°C unless otherwise specified)

ITEM	SYMBOL	CONDITIONS	MIN	TYPE	MAX	UNITS	Test circuits
Output voltage	V _{OUT}	V _{IN} = 4.6V, I _{OUT} =50mA	3.528	3.6	3.672	V	1
Output current *1	I _{OUT}	V _{IN} = 4.6V	500			mA	3
Dropout voltage *2	V _{drop}	I _{OUT} =10 mA I _{OUT} =200mA		10 200	14 280	mV	1
Line regulation	$\frac{\Delta V_{OUT1}}{\Delta V_{IN} \cdot V_{OUT}}$	4.6V ≤ V _{IN} ≤ 10V I _{OUT} =1mA		0.05	0.2	%/V	
Load regulation	ΔV _{OUT2}	V _{IN} =4.6V 1.0mA ≤ I _{OUT} ≤ 200mA		30	45	mV	
Temperature coefficient	$\frac{\Delta V_{OUT}}{\Delta T_a \cdot V_{OUT}}$	V _{IN} =4.6V, I _{OUT} =10mA -40°C ≤ T _a ≤ 85°C		±50	±100	Ppm/°C	
Current consumption	I _{SS1}	V _{IN} =10V No Load		1.2	2.5	μA	2
Input voltage	V _{IN}	--			10	V	
Short current limit	I _{lim}	V _{out} =0V		50	70	mA	

AMS53XX series (MD5338, Output voltage +3.8V) (Ta=25°C unless otherwise specified)

ITEM	SYMBOL	CONDITIONS	MIN	TYPE	MAX	UNITS	Test circuits
Output voltage	V _{OUT}	V _{IN} = 4.8V, I _{OUT} =50mA	3.724	3.8	3.876	V	1
Output current *1	I _{OUT}	V _{IN} = 4.8V	500			mA	3
Dropout voltage *2	V _{drop}	I _{OUT} =10 mA I _{OUT} =200mA		10 200	14 280	mV	1
Line regulation	$\frac{\Delta V_{OUT1}}{\Delta V_{IN} \cdot V_{OUT}}$	4.8V ≤ V _{IN} ≤ 10V I _{OUT} =1mA		0.05	0.2	%/V	
Load regulation	ΔV _{OUT2}	V _{IN} =4.8V 1.0mA ≤ I _{OUT} ≤ 200mA		30	45	mV	
Temperature coefficient	$\frac{\Delta V_{OUT}}{\Delta T_a \cdot V_{OUT}}$	V _{IN} =4.8V, I _{OUT} =10mA -40°C ≤ T _a ≤ 85°C		±50	±100	Ppm/°C	
Current consumption	I _{SS1}	V _{IN} =10V No Load		1.2	2.5	μA	2
Input voltage	V _{IN}	--			10	V	
Short current limit	I _{lim}	V _{out} =0V		50	70	mA	

AMS53XX series(MD5344, Output voltage +4.4V) (Ta=25°C unless otherwise specified)

ITEM	SYMBOL	CONDITIONS	MIN	TYPE	MAX	UNITS	Test circuits
Output voltage	V _{OUT}	V _{IN} = 5.4V, I _{OUT} =50mA	4.312	4.4	4.488	V	1
Output current *1	I _{OUT}	V _{IN} = 5.4V	500			mA	3
Dropout voltage *2	V _{drop}	I _{OUT} =10 mA I _{OUT} =200mA		10 200	14 280	mV	1
Line regulation	$\frac{\Delta V_{OUT1}}{\Delta V_{IN} \cdot V_{OUT}}$	5.4V ≤ V _{IN} ≤ 10V I _{OUT} =1mA		0.05	0.2	%/V	
Load regulation	ΔV _{OUT2}	V _{IN} =5.4V 1.0mA ≤ I _{OUT} ≤ 200mA		30	45	mV	
Temperature coefficient	$\frac{\Delta V_{OUT}}{\Delta T_a \cdot V_{OUT}}$	V _{IN} =5.4V, I _{OUT} =10mA -40°C ≤ T _a ≤ 85°C		±50	±100	Ppm/°C	
Current consumption	I _{SS1}	V _{IN} =10V No Load		1.2	2.5	μA	2
Input voltage	V _{IN}	--			10	V	
Short current limit	I _{lim}	V _{out} =0V		50	70	mA	

AMS53XX series(MD5350, Output voltage +5.0V) (Ta=25°C unless otherwise specified)

ITEM	SYMBOL	CONDITIONS	MIN	TYPE	MAX	UNITS	Test circuits
Output voltage	V _{OUT}	V _{IN} = 6V, I _{OUT} =50mA	4.900	5.0	5.100	V	1
Output current *1	I _{OUT}	V _{IN} = 6V	500			mA	3
Dropout voltage *2	V _{drop}	I _{OUT} =10 mA I _{OUT} =200 mA		10 200	14 280	mV	1
Line regulation	$\frac{\Delta V_{OUT1}}{\Delta V_{IN} \cdot V_{OUT}}$	6V ≤ V _{IN} ≤ 10V I _{OUT} =1mA		0.05	0.2	%/V	
Load regulation	ΔV _{OUT2}	V _{IN} =6V 1.0mA ≤ I _{OUT} ≤ 200mA		30	45	mV	
Temperature coefficient	$\frac{\Delta V_{OUT}}{\Delta T_a \cdot V_{OUT}}$	V _{IN} =6V, I _{OUT} =10mA -40°C ≤ T _a ≤ 85°C		±50	±100	Ppm/°C	
Current consumption	I _{SS1}	V _{IN} =10V No Load		1.2	2.5	μA	2
Input voltage	V _{IN}	--			15	V	
Short current limit	I _{lim}	V _{out} =0V		50	70	mA	

* 1.Increasing output current slowly, The I_{OUT} when output voltage decreasing two percent

* 2.V_{drop}=V_{IN1}- (V_{OUT (E)} × 0.98V)

V_{OUT (E)} Effective output voltage, i. e., the output voltage when fixing I_{OUT}(1mA) and inputting V_{OUT(S)} 2.0 V.

V_{IN1}: is the Input voltage at which output voltage becomes 98 of V_{OUT (E)} after gradually decreasing input voltage

Application Circuits:

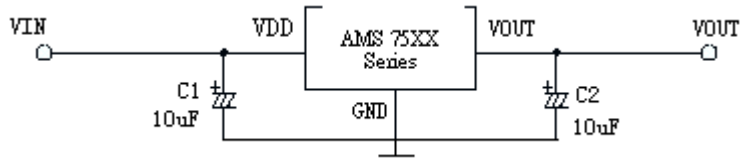

Figure 2

Test Circuits

1.



图 1

2.

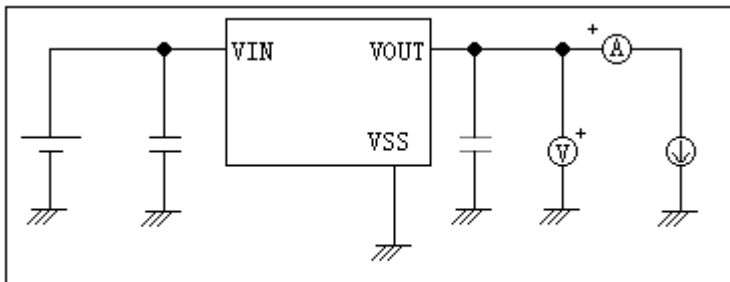

图 2

3.

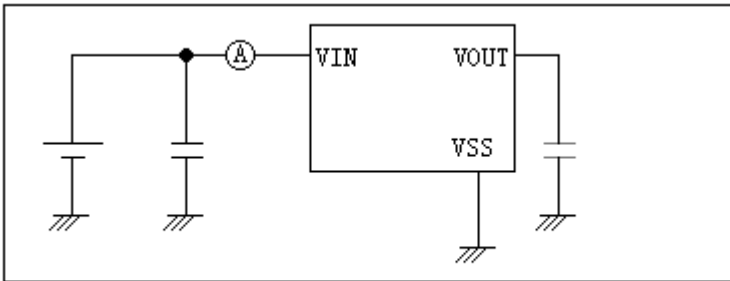

图 3

Figure 3

Standard Circuit

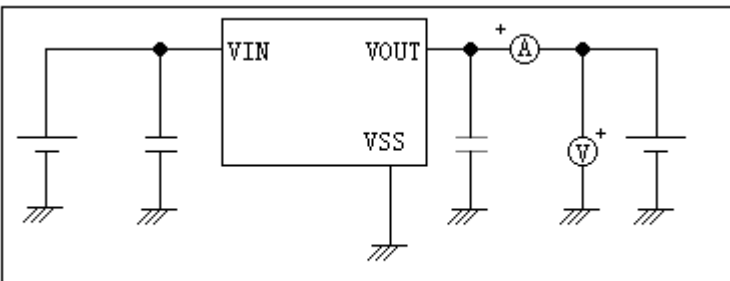
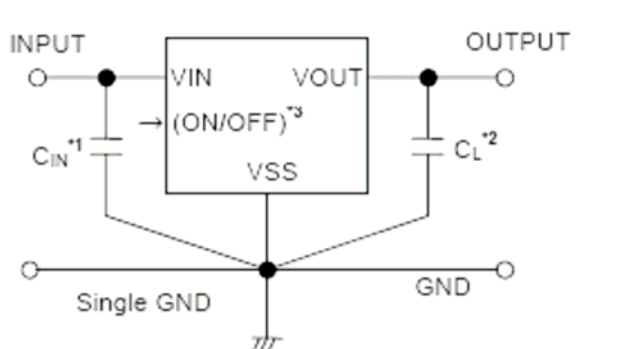

Figure 7

- *1. C_{IN} is a capacitor for stabilizing the input.
- *2. A ceramic capacitor can be used for C_L besides a tantalum capacitor.
- *3. In case of product with shutdown function.

Caution The above connection diagram and constant will not guarantee successful operation.

Perform through evaluation using the actual application to set the constant.

Input capacitors(C_{IN}): $>1.0 \mu\text{F}$.

Output capacitors(C_L): $>2.2 \mu\text{F}$ (tantalum capacitors) Or
 $>10.0 \mu\text{F}$ (aluminum capacitors).

■ Technical Terms

1. Output capacitors (C_L)

Output capacitors are generally used to stabilize regulation operation and to improve transient response characteristics. But the AMS53XX series can provide stable operation without output capacitors. Capacitors are used only to improve transient response characteristics. Output capacitors can hence be removed in applications in which transient response can be negligible. When an output capacitor is used, a low ESR (Equivalent Series Resistance) capacitor like ceramic capacitor can also be used.

2. Output voltage (V_{OUT})

The accuracy of the output voltage is $\pm 2.0\%$ guaranteed under the specified conditions for input voltage, which differs depending upon the product items, output current, and temperature.

Caution: If the above conditions change, the output voltage value may vary and go out of the accuracy range of the output voltage. See the electrical characteristics and characteristics data for details.

3. Line regulations ($\Delta V_{OUT1} / \Delta V_{IN} * V_{OUT}$)

These parameters indicate the input voltage dependence on the output voltage. That is, the values show how much the output voltage changes due to a change in the input voltage with the output current remained unchanged.

4. Load regulation (ΔV_{OUT2})

This parameter indicates the output current dependence on the output voltage. That is, the value shows how much the output voltage changes due to a change in the output current with the input voltage remained unchanged.

5. Dropout voltage (V_{drop})

This parameter indicates the difference between the input voltage (V_{IN1}) and the output voltage when

output voltage falls to 98 % of $V_{OUT(E)}$ by gradually decreasing the input voltage (V_{IN}).

$$V_{drop} = V_{IN1} - [V_{OUT(E)} \times 0.98]$$

■ Description of Operation

1. Basic Operation

Figure 8 shows the block diagram of the AMS53XX series. The error amplifier compares a reference voltage V_{ref} with a part of the output voltage divided by the feedback resistors R_s and R_f , and supplies the gate voltage to the output transistor, necessary to ensure certain output voltage independent from change of input voltage and temperature.

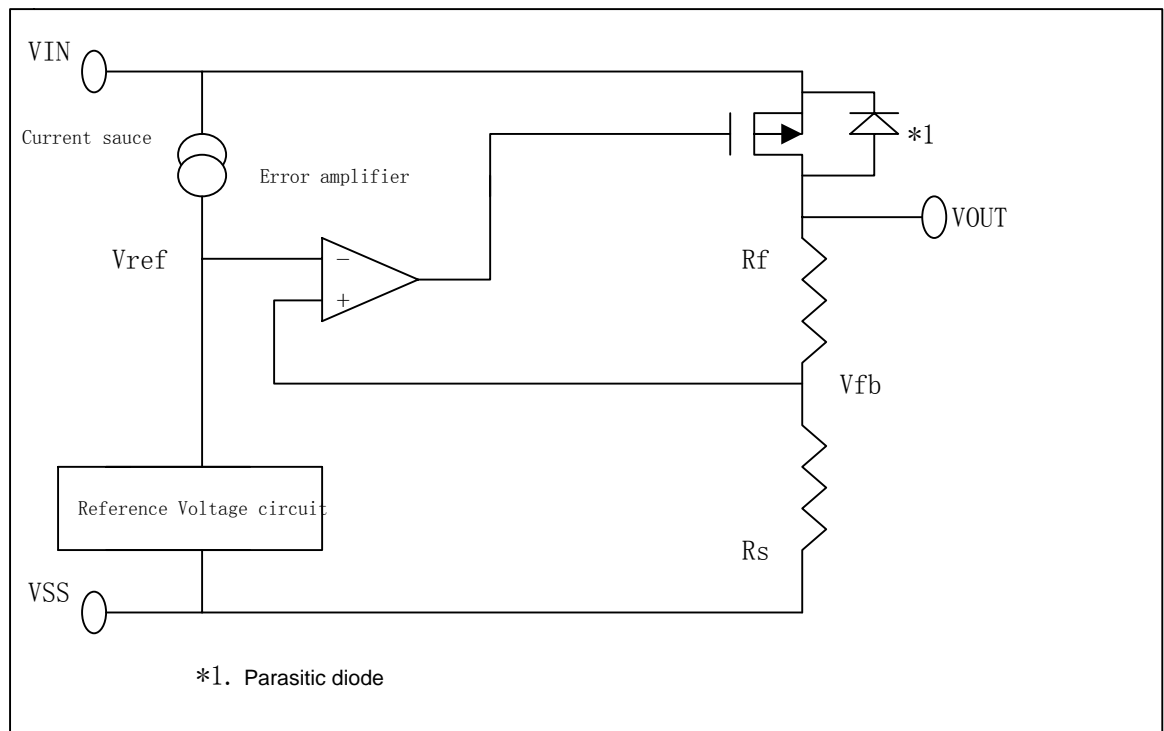

Figure 8

2. Output Transistor

The AMS53XX Series uses a Pch MOS FET as the output transistor.

The voltage at VOUT must not exceed $V_{IN}+0.3V$. When the VOUT voltage becomes higher than that of V_{IN} , reverse current flows and may break the regulator since a parasitic diode between VOUT and VIN exists inevitably

3. Shutdown function (ON/OFF pin)

The ON/OFF pin controls the start and stop of the regulation operation.

When the ON/OFF pin is set to shutdown level, halting whole internal circuit and turning off the Pch MOS FET between VIN and VOUT, current consumption is drastically reduced. The voltage of the VOUT pin becomes VSS level due to the internal resistance divider of several $M\Omega$ between VOUT and VSS. The ON/OFF pin should not be left afloat since no pull-up nor pull-down is made internally as shown in figure 9. Note also that a current will flow to the VIN side via the parasitic diode inside the IC if a voltage of $V_{IN} + 0.3V$ or more is applied. When the shutdown function is not used, connect the pin to the VIN pin in case of positive logic and to the VSS pin in case of negative logic. When a regulation operation at light load less than $100\ \mu A$ is halted, output voltage may increase. If the increase of the output voltage should be avoided, pull down the VOUT pin to the Vss level as soon as ON/OFF pin goes to the shutdown level.

Logic Type	ON/OFF Pin	Internal Circuits	VOUT Pin Voltage	Current Consumption
B	“L” : Power off	Stopped	Vss level	I _{SS2}
B	“H” : Power on	on Operating	Set value	I _{SS1}

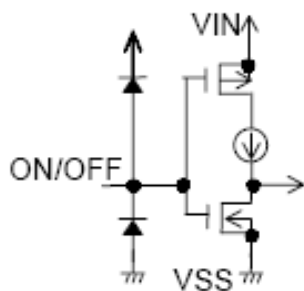

Figure 9

4. Short-circuit protection

Installation of the short-circuit protection which protects the output transistor against short-circuit between VOUT and VSS can be selected in the AMS53XX series. The short-circuit protection controls output current as shown in the typical characteristics, (1) OUTPUT VOLTAGE versus OUTPUT CURRENT, and suppresses output current at about 40 mA even if VOUT and VSS pins are short-circuited.

The short-circuit protection can not at the same time be a thermal protection. Attention should be paid to the Input voltage and the load current under the actual condition so as not to exceed the power dissipation of the package including the case for short-circuit.

When the output current is large and the difference between input and output voltage is large even if not shorted, the short-circuit protection may work and the output current is suppressed to the specified value. Products without short-circuit protection can provide comparatively large current by removing a short-circuit protection.

■ Selection of External Components

Output Capacitor (C_L)

The AMS53XX series can provide stable operation without output capacitor (C_L) since the regulator has an internal phase compensation circuit to stabilize operation when the load changes. The transient response of the regulator, however, changes with the output capacitor and the magnitude of overshoot and undershoot on output voltage accordingly changes. Please refer to C_L dependence data in “Transient Response Characteristics” to select suitable value for the capacitor.

When a tantalum or an aluminum electrolytic capacitor is used, the ESR of the capacitor shall be $10\ \Omega$ or less. When an aluminum electrolytic capacitor is used attention should be especially paid to since the ESR of the aluminum electrolytic capacitor increases at low temperature and possibility of oscillation becomes large. Sufficient evaluation including temperature characteristics is indispensable.

■ Precautions:

- Design wiring patterns for VIN, VOUT and GND pins to hold low impedance.

When mounting an output capacitor between the VOUT and VSS pins (C_L) and a capacitor for stabilizing the input between VIN and VSS pins (C_{IN}), the distance from the capacitor to the VOUT pin and to the VSS pin should be as short as possible.

- Note that output voltage may be increased at low load current of less than 1 μ A.
- To prevent oscillation, it is recommended to use the external parts under the following conditions.

Equivalent Series Resistance (ESR): $30\ \Omega$ or less

Input series resistance (R_{IN}): $10\ \Omega$ or less

- A voltage regulator may oscillate when power source impedance is high and input capacitor is low or not connected.
- The application condition for input voltage and load current should not exceed the package power dissipation.
- Pay attention to the operating conditions for input/output voltage and load current so that the power loss in the IC does not exceed the power dissipation of the package.
- Do not apply an electrostatic discharge to this IC that exceeds the performance ratings of the built-in electrostatic protection circuit.
- SII claims no responsibility for any and all disputes arising out of or in connection with any infringement of the products including this IC upon patents owned by a third party.

Application Circuits

Basic Circuits

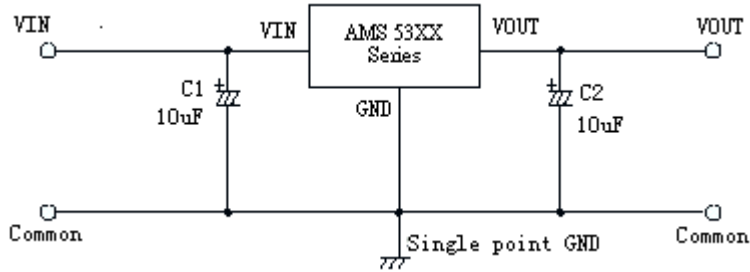

High Output Current Positive Voltage Regulator

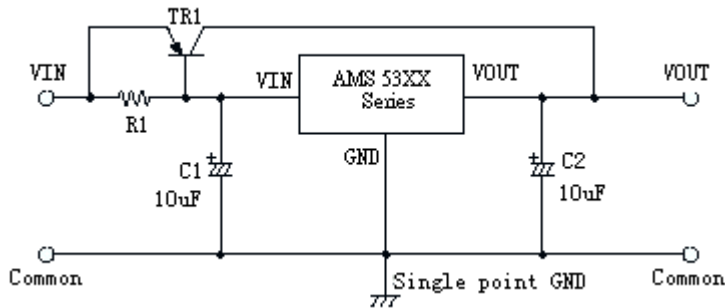

Short-Circuit Protection by Tr1

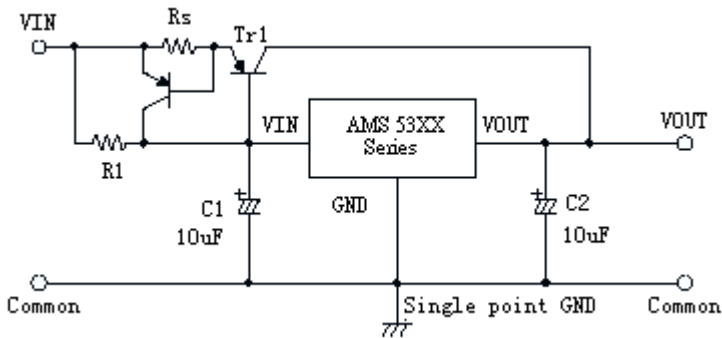

Circuit for Increasing Output Voltage

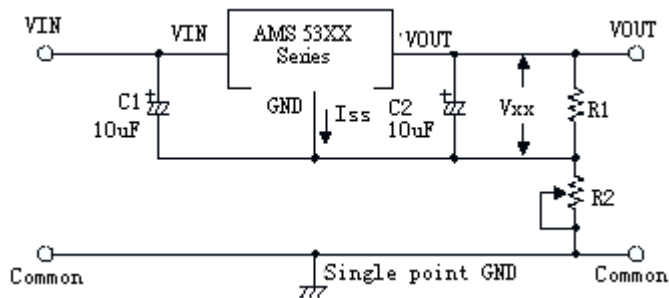

$$V_{out} = V_{xx} (1 + R2/R1) + I_{ss} R2$$

Circuit for Increasing Output Voltage

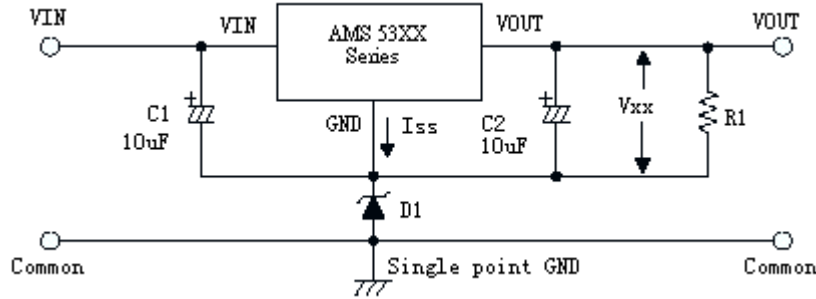

$$V_{OUT} = V_{XX} + V_{D1}$$

Constant Current Regulator

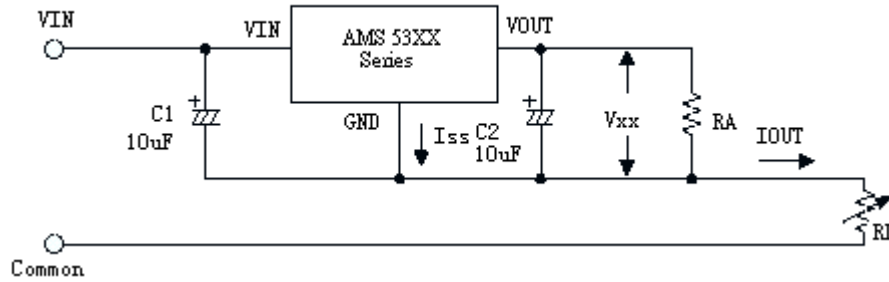

$$I_{OUT} = V_{XX} / R_A + I_{SS}$$

Dual Supply

